



ALPHA DATA

ADM-VPX3-9Z5

User Manual

Document Revision: 1.3
30th May 2022

**© 2022 Copyright Alpha Data Parallel Systems Ltd.
All rights reserved.**

This publication is protected by Copyright Law, with all rights reserved. No part of this publication may be reproduced, in any shape or form, without prior written consent from Alpha Data Parallel Systems Ltd.

Head Office

Address: Suite L4A, 160 Dundee Street,
Edinburgh, EH11 1DQ, UK
Telephone: +44 131 558 2600
Fax: +44 131 558 2700
email: sales@alpha-data.com
website: <http://www.alpha-data.com>

US Office

10822 West Toller Drive, Suite 250
Littleton, CO 80127
(303) 954 8768
(866) 820 9956 - toll free
sales@alpha-data.com
<http://www.alpha-data.com>

All trademarks are the property of their respective owners.

Table Of Contents

1	Introduction	1
1.1	Key Features	1
1.2	References & Specifications	1
1.3	Order Code	1
2	Installation	3
2.1	Handling Instructions	3
2.2	Hardware Installation	3
2.2.1	System Requirements	3
2.2.2	Cooling Requirements	3
2.3	Software Installation	4
3	Functional Description	5
3.1	Overview	5
3.1.1	Switch Definitions	6
3.1.2	LED Definitions	7
3.2	VPX P0 Interface	9
3.2.1	SYSRESET#	9
3.2.2	AUXCLK	9
3.2.3	REFCLK	9
3.3	VPX P1 GPIO	9
3.3.1	Differential / Low Voltage GPIO	9
3.3.2	Single Ended PSMIO GPIO	9
3.4	VPX P2 GPIO	10
3.4.1	Differential / Low Voltage GPIO	10
3.4.2	Single Ended GPIO	10
3.5	JTAG Interface	11
3.5.1	On-board Interface	11
3.5.2	VPX Interface	11
3.5.3	JTAG Voltages	11
3.6	Clocks	12
3.6.1	IO Delay Reference Clock (FABRIC_CLK)	13
3.6.2	IO Delay Reference Clock (MEM_CLK)	13
3.6.3	Fixed 100MHz Reference clock REFCLK100M	13
3.6.4	Selectable Clocks (CLKA and CLKB)	13
3.6.5	Module to Carrier Global Clocks (CLK_M2C)	14
3.6.6	Module to Carrier MGTREF Clocks (GBTCLK_M2C)	14
3.6.7	PS_REFCLK	14
3.7	Resets	15
3.8	Zynq PS Block	15
3.8.1	Boot Modes	15
3.8.2	PS Memory Interfaces	15
3.8.2.1	Quad SPI Flash Memory	15
3.8.2.2	MicroSD Card	15
3.8.2.3	PS DDR4 Memory	15
3.8.3	PS MIO	15
3.8.4	PS MGT Links	16
3.9	Zynq PL Block	16
3.9.1	I/O Bank Voltages	16
3.9.2	PL MGT Links	16
3.9.3	FMC+ GPIO Interface	17
3.9.4	VPX P1 GPIO Interface	17
3.9.5	VPX P2 GPIO Interface	17
3.9.6	PL DDR4 Memory	18

3.10	System Monitoring	18
3.10.1	Automatic Temperature Monitoring	18
3.10.2	System Monitor Status LEDs	19
3.11	FMC Interface and Front-Panel I/O	19
Appendix A P1 Pin Assignments		21
A.1	Data Plane 1 (P1 Wafers 1-4)	21
A.2	Data Plane 2 (P1 Wafers 5-8)	21
A.3	User Plane PS GTR(P1 Wafers 9-10)	22
A.4	User Plane GPIO(P1 Wafers 11-12)	22
A.5	User Plane PS MIO(P1 Wafers 9-14)	22
A.6	Control Plane (P1 Wafers 15-16)	22
Appendix B P2 Pin Assignments		23
B.1	GPIO (P2 Wafers 1-4)	23
B.2	MGT Pins (P2 Wafers 5-16)	23
Appendix C FMC Pin Assignments		25
C.1	GPIO Pins	25
C.2	Clock Pins	27
C.3	MGT Pins	28

List of Tables

Table 1	References	1
Table 2	Build Options	2
Table 3	Processor Setup Switch Definitions (SW1)	6
Table 4	VPX Control Switch Definitions (SW2)	6
Table 5	Status LED Definitions	8
Table 6	User Defined LEDs	8
Table 7	FABRIC_CLK Connections	13
Table 8	MEM_CLK Connections	13
Table 9	REFCLK100M Connections	13
Table 10	CLKA Connections	13
Table 11	CLKB Connections	14
Table 12	CLK_M2C Connections	14
Table 13	GCLK_M2C Connections	14
Table 14	PS_REFCLK Connection	15
Table 15	Reset Switches	15
Table 16	Boot Mode Selection	15
Table 17	VPX PS MIO Groups	16
Table 18	PS MGT Links	16
Table 19	PL FPGA IO Banks	16
Table 20	PL MGT Links	16
Table 21	FMC+ Groups (J1)	17
Table 22	VPX P1 GPIO Groups	17
Table 23	VPX P2 GPIO Groups	18
Table 24	Voltage and Temperature Monitors (in microcontroller)	18
Table 25	Temperature Limits	19
Table 26	System Monitor Status LEDs	19
Table 27	Data Plane 1 (P1 Wafers 1-4)	21
Table 28	Data Plane 2 (P1 Wafers 5-8)	21
Table 29	User Plane PS GTR(P1 Wafers 9-10)	22
Table 30	User Plane GPIO(P1 Wafers 11-12)	22

Table 31	User Plane PS MIO(P1 Wafers 9-14)	22
Table 32	Control Plane (P1 Wafers 15-16)	22
Table 33	GPIO (P2 Wafers 1-4)	23
Table 34	MGT (P2 Wafers 5-16)	23
Table 35	GPIO Pins	25
Table 36	Clock Pins	27
Table 37	MGT Pins	28

List of Figures

Figure 1	ADM-VPX3-9Z5	4
Figure 2	ADM-VPX3-9Z5 Block Diagram	5
Figure 3	LED Locations	7
Figure 4	JTAG Boundary Scan Chain	11
Figure 5	Clocks	12

Page Intentionally left blank

1 Introduction

The ADM-VPX3-9Z5 is a high performance Defense Grade reconfigurable 3U OpenVPX format board based on the Xilinx Zynq Ultrascale+ range of Multiprocessor System-on-Chips (MPSoC).

1.1 Key Features

Key Features

- 3U Open VPX, compliant to VITA Standards 46.0 and 65
- All parts shall be Defense Grade -55 to +125 Deg C (or commercial pin compatible equivalent)
- FMC+ interface compliant to Vita 57.4 with high density connector
- Support for Zynq Ultrascale+ ZU19EG and ZU11EG MPSoC in the C1760 (42.5 x 42.5) package
- Support for Xilinx low-voltage (LVAUX) operation
- VPX P1 and P2 utilized according to OpenVPX payload slot profile SLT3-PAY-2F2U-14.2.3
- Processing System (PS) Block consisting of:
 - Quad-core ARM Cortex-A53, Dual-core ARM Cortex-R5, Mali-400 GPU
 - 1 bank of DDR4-2400 SDRAM, 1GB x72, 8GB total + ECC
 - Removable microSD Flash memory (/DEV variant only)
 - Two Quad SPI Flash memory, up to 2Gb each
- Programmable Logic (PL) block consisting of:
 - 653k logic cells (ZU11EG) or 1143k logic cells (ZU19EG)
 - 1 bank of DDR4-2400 SDRAM, 1GB x72, 8GB total + ECC
- 4-lanes of HSSIO on the PS block which connect to the control plane and the user defined area on P1.
- Voltage and temperature monitoring
- Air-cooled and conduction-cooled configurations

1.2 References & Specifications

ANSI/VITA 46.0	<i>VPX Baseline Standard, October 2007, VITA, ISBN 1-885731-44-2</i>
ANSI/VITA 46.4	<i>PCI Express® on the VPX Fabric Connector, July 2010, VITA, Draft 0.15</i>
ANSI/VITA 46.6	<i>Gigabit Ethernet Control Plane on VPX, September 2010, VITA, Draft 0.7</i>
ANSI/VITA 46.9	<i>PMC/XMC Rear I/O Fabric Signal Mapping on 3U and 6U VPX Modules Standard, November 2010, VITA, ISBN 1-885731-63-9</i>
ANSI/VITA 46.11	<i>System Management on VPX, June 2015, VITA, ISBN 1-885731-84-1</i>
ANSI/VITA 48.2	<i>Mechanical Specifications for Microcomputers Using REDI Conduction Cooling Applied to VITA VPX, July 2010, VITA, ISBN 1-885731-60-4</i>
ANSI/VITA 57.1	<i>FPGA Mezzanine Card (FMC) Standard, July 2008, VITA, ISBN 1-885731-49-3</i>
ANSI/VITA 65	<i>OpenVPX™ System Specification, June 2010, VITA, ISBN 1-885731-58-2</i>
ANSI/VITA 57.4	<i>FPGA Mezzanine Card Plus(FMC+) Standard, March 2016, VITA, Draft</i>

Table 1 : References

1.3 Order Code

ADM-VPX3-9Z5/z-2(c)

Name	Symbol	Configurations
Configuration	T	/CC4/PB = XQZU19EG-1M Q Grade FPGA / Cond. Cooled MIL temp / Sn-Pb Solder /Z19-2/CC3/PB = XQZU19EG-2I Q Grade FPGA / Cond. Cooled IND temp / Sn-Pb Solder

Table 2 : Build Options

Not all combinations may be available. Please check with Alpha Data sales for details.

2 Installation

2.1 Handling Instructions

The components on this board can be damaged by electrostatic discharge (ESD). To prevent damage, observe ESD precautions:



- Always wear a wrist-strap when handling the card
- Hold the board by the edges
- Avoid touching any components
- Store in ESD safe bag.

2.2 Hardware Installation

2.2.1 System Requirements

The ADM-VPX3-9Z5 is a 3U OpenVPX compliant FPGA card with FMC front IO interface.

Alpha Data offers a Rear Transition Module (RTM) that breaks out all P2 IO and P1 control lanes (Part number: ADM-VPX3-9Z5-RTM).

2.2.2 Cooling Requirements

The power dissipation of the board is highly dependent on the FPGA application. A power estimator spreadsheet is available on request from Alpha Data. This should be used in conjunction with Xilinx power estimation tools to determine the approximate current requirements for each power rail.

The board is supplied with a passive air cooled or conduction cooled heatsink according to the order number given at time of purchase. It is the users responsibility to ensure sufficient airflow for air cooled applications and appropriate metalwork for conduction cooled applications.

The board features system monitoring that measures the board and FPGA temperature. It also includes a self-protection mechanism that will clear the target FPGA configuration if an over-temperature condition is detected.

See [Section System Monitoring](#) for health monitoring details.

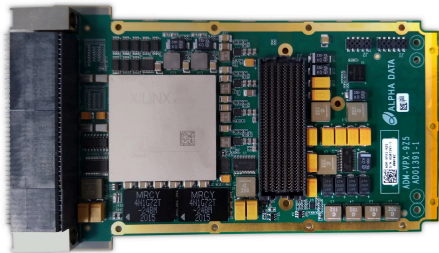

Figure 1 : ADM-VPX3-9Z5

2.3 Software Installation

Please refer to the Reference Designs on the Alpha Data Download Site. Example projects for configuring the Zynq UltraScale+ MPSOC device and example software for running on the ARM CPUs can be downloaded from there.

3.1.1 Switch Definitions

There are two sets of eight DIP switches placed on the bottom of the board. Their functions are described below.

Note:

All switches are OFF by default. Factory Configuration switch must be in the OFF position for normal operation.

Switch Ref.	Function	ON State	Off State
SW1-(4:1)	PS_MODE(3:0)	PS Boot Mode - see section Boot Modes	
SW1-5	Hardware Reset	Hardware Reset (complete restart)	Normal Operation
SW1-6	Software Reset	Software Reset (warm reset)	Normal Operation
SW1-7	PS_SE_EN	PS Single Ended enabled	PS Single Ended disabled
SW1-8	P2_SE_EN	P2 Single Ended enabled	P2 Single Ended disabled

Table 3 : Processor Setup Switch Definitions (SW1)

Switch Ref.	Function	ON State	Off State
SW2-1	P1_LVDS_EN	P1 low voltage GPIO Enabled	P1 low voltage GPIO Disabled
SW2-2	CLKA_SEL	CLKA = 100MHz	CLKA = 125MHz
SW2-3	CLKB_SEL	CLKB = 161.13MHz	CLKB = 156.25MHz
SW2-4	User Switch	PSMIO26=logic low	PSMIO26=logic high
SW2-5	VPX JTAG	Connect JTAG chain to P0	Isolate JTAG chain from P0
SW2-6	P2_LVDS_EN	P2 low voltage GPIO Enabled	P2 low voltage GPIO Disabled
SW2-7	Factory Configuration	-	Normal Operation
SW2-8	LVAUX_EN	LVAUX mode enabled	Normal Operation

Table 4 : VPX Control Switch Definitions (SW2)

3.1.2 LED Definitions

There are seven LEDs to provide a visual indication of the board status.

Their locations are shown in [Figure 3](#)

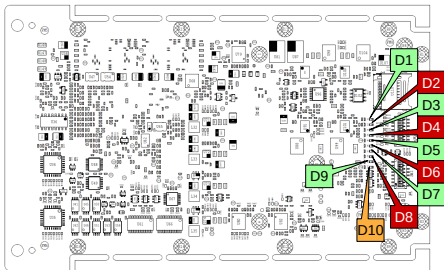

Figure 3 : LED Locations

Comp. Ref.	Function	ON State	Off State
D3 (Green)	System Monitor Status	See Table 26	
D6 (Red)	System Monitor Status	See Table 26	
D9 (Green)	FPGA (PL) Done	PL is configured	PL is not configured
D10 (Amber)	VPX JTAG STATUS	JTAG chain Connected to VPX P0	JTAG chain isolated from VPX P0
D2 (Red)	Power Fault	Power Supply Fault	Power Supplies off or within range
D8 (Red)	PS Error	PS Error	Normal Operation
D7 (Green)	PS Status	Normal Operation	PS is in Reset / Error

Table 5 : Status LED Definitions

There also are three user defined LEDs available:

Comp. Ref.	FPGA Pin	Bank	Operation
D4 (Red)	D9	PL Bank 93	Logic low = LED ON
D5 (Green)	C9	PL Bank 93	Logic low = LED ON
D1 (Green)	U28	PSMIO 46	Logic low = LED ON

Table 6 : User Defined LEDs

3.2 VPX P0 Interface

3.2.1 SYSRESET#

When the 9Z5 is NOT acting as the system controller:

- SYSRESET# is an active low input from the system controller
- SYSRESET# is connected to the FPGA PL side PERSTN0 PCIe reset pin on Bank 65 (Pin AM25)
- SYSRESET# is connected to the FPGA PS side PS_POR_B hard reset pin on Bank 503 (Pin W27)

When the 9Z5 is acting as the system controller:

- SYSRESET# is an active low output to the rest of the system
- SYSRESET# is driven from PSMIO 56 (Pin AA30)

3.2.2 AUXCLK

Auxiliary Clock. In OpenVPX this clock line can be used for 1PPS synchronization signaling and is an INPUT to the FPGA at Bank93 pin G8 (LVCMOS33) .

3.2.3 REFCLK

Reference Clock. This clock is an input to the onboard clock distribution and generation system. In OpenVPX this 50MHz clock can be used to align all system clocks.

When the 9Z5 is NOT acting as a system controller this clock is an INPUT to the FPGA at Bank93 pin F8 (LVCMOS33)

When the 9Z5 IS acting as a system controller this clock is an OUTPUT from the FPGA at Bank93 pin G7 (LVCMOS33)

3.3 VPX P1 GPIO

3.3.1 Differential / Low Voltage GPIO

In normal operating mode these differential GPIO on P1 are compatible with 1.8V signaling such as LVDS and 1.8V single ended signals.

In LVAUX operating mode the GPIO on P1 are compatible with 1.2V signaling such as LVDS_12 and 1.2V single ended signals.

These signals are routed differentially to/from FPGA Bank 67 and are enabled / disabled via switch SW2-1.

The FPGA can NOT accept signal levels above 1.8V (normal operation) or above 1.2V (LVAUX mode) on these signals, **otherwise damage to the FPGA device may occur.**



Care must be taken to ensure that the acceptable signal limits will not be exceeded prior to enabling these GPIO lines.

3.3.2 Single Ended PSMIO GPIO

The Single Ended GPIO on P1 are compatible with 3.3V single ended signals and are routed from PSMIO on Bank 501.

The FPGA is protected from inappropriate signal levels by a low resistance quick switch and can accept up to 3.3V on an input.

These signals are are enabled / disabled via switch SW1-7.

3.4 VPX P2 GPIO

3.4.1 Differential / Low Voltage GPIO

In normal operating mode the differential GPIO on P2 are compatible with 1.8V signaling such as LVDS and 1.8V single ended signals.

In LVAUX operating mode the GPIO on P2 are compatible with 1.2V signaling such as LVDS_12 and 1.2V single ended signals.

These signals are routed differentially to/from FPGA Bank 67 and are enabled / disabled via switch SW2-6.

The FPGA can NOT accept signal levels above 1.8V (normal operation) or above 1.2V (LVAUX mode) on these signals, **otherwise damage to the FPGA device may occur.**



Care must be taken to ensure that the acceptable signal limits will not be exceeded prior to enabling these GPIO lines.

3.4.2 Single Ended GPIO

The Single Ended GPIO on P2 are routed to/from FPGA bank 94 and are compatible with 3.3V single ended signals.

The FPGA is protected from inappropriate signal levels by a low resistance quick switch and can accept up to 3.3V on an input.

These signals are enabled / disabled via switch SW1-8.

3.5 JTAG Interface

3.5.1 On-board Interface

A JTAG boundary scan chain is connected to header J1. This allows the connection of the Xilinx JTAG cable via adapter board AD-JTAG-ADPT2.

Adapter board AD-JTAG-ADPT2 should be inserted into header J1 through the rear of the board, header J1 is keyed to ensure correct orientation.

The scan chain is shown in [Figure JTAG Boundary Scan Chain](#):

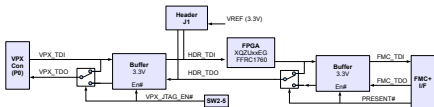

Figure 4 : JTAG Boundary Scan Chain

If the boundary scan chain is connected to the interface at the VPX backplane (SW2-5 is ON), header J1 should not be used.

3.5.2 VPX Interface

The JTAG interface on the VPX backplane is normally unused. When SW2-5 is OFF (default), all JTAG signals to P0 are left floating.

The JTAG interface can be connected to the VPX Backplane (through level-translators) by switching SW2-5 ON.

3.5.3 JTAG Voltages

The on-board JTAG scan chain uses 3.3V. The Vcc supply provided on J1 to the JTAG cable is +3.3V and is protected by a poly fuse rated at 350mA.

The JTAG signals at the VPX interface use 3.3V signal levels and are connected through buffers to the on-board scan chain.

The JTAG signals at the FMC interface also use 3.3V signal levels and are connected through buffers to FMC boards scan chain.

3.6 Clocks

The **ADM-VPX3-9Z5** board provides a wide variety of clocking options. In addition to the clocks routed from the FMC+ connector, the board has 4 selectable fixed frequency clock sources. These clocks can be combined with the FPGA's internal PLLs to suit a wide variety of communication protocols.

A complete overview of the clock routing on the **ADM-VPX3-9Z5** is given in [Clocks](#). A description of each clock follows.

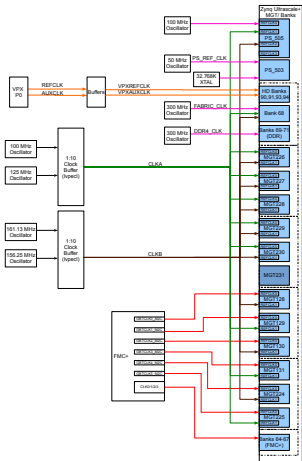

Figure 5 : Clocks

3.6.1 IO Delay Reference Clock (FABRIC_CLK)

The fixed reference clock FABRIC_CLK is a differential LVDS signal.

FABRIC_CLK is used as the reference clock for the IO delay control block (IDELAYCTRL).

Signal	Frequency	Target FPGA Input	IO Standard	"P" pin	"N" pin
FABRIC_CLK	300 MHz	IO BANK 67	LVDS	AT13	AT12

Table 7 : FABRIC_CLK Connections

3.6.2 IO Delay Reference Clock (MEM_CLK)

The fixed reference clock MEM_CLK is a differential LVDS signal.

MEM_CLK is used as the reference clock for the PL DDR memory logic.

Signal	Frequency	Target FPGA Input	IO Standard	"P" pin	"N" pin
MEM_CLK	300 MHz	IO BANK 67	LVDS	AT11	AT10

Table 8 : MEM_CLK Connections

3.6.3 Fixed 100MHz Reference clock REFCLK100M

A fixed 100MHz reference clock is available on the board.

Signal	Frequency	Target FPGA Input	IO Standard	"P" pin
REFCLK100M	100 MHz	PS_505_MGTREFCLK_0	LVDS	AG37

Table 9 : REFCLK100M Connections

3.6.4 Selectable Clocks (CLKA and CLKB)

There are two selectable clock sources that are forwarded throughout the FPGA. CLKA can be set to either 100MHz or 125MHz. CLKB can be set to either 161.13MHz or 156.25MHz.

Signal	Target FPGA Input	IO Standard	"P" pin	"N" pin
CLKA[0]	PS_505_MGTREFCLK_1	LVPECL	AE37	AE38
CLKA[1]	Bank 67	LVDS	AP10	AR10
CLKA[2]	MGTREFCLK_224	LVPECL	AK12	AK11
CLKA[3]	MGTREFCLK_225	LVPECL	AH12	AH11
CLKA[4]	MGTREFCLK_226	LVPECL	AF12	AF11
CLKA[5]	MGTREFCLK_227	LVPECL	AD12	AD11
CLKA[6]	MGTREFCLK_228	LVPECL	AB12	AB11
CLKA[7]	MGTREFCLK_129	LVPECL	U32	U33
CLKA[8]	MGTREFCLK_131	LVPECL	J32	J33
CLKA[9]	MGTREFCLK_230	LVPECL	U10	U9

Table 10 : CLKA Connections

Note: CLKA[9:0] are all buffered copies of the same clock signal.

Signal	Target FPGA Input	IO Standard	"P" pin	"N" pin
CLKB[0]	PS_505_MGTREFCLK_2	LVPECL	AC37	AC38
CLKB[1]	Bank 67	LVDS	AR13	AR12
CLKB[2]	MGTREFCLK_224	LVPECL	AJ10	AJ9
CLKB[3]	MGTREFCLK_225	LVPECL	AG10	AG9
CLKB[4]	MGTREFCLK_226	LVPECL	AE10	AE9
CLKB[5]	MGTREFCLK_227	LVPECL	AC10	AC9
CLKB[6]	MGTREFCLK_228	LVPECL	AA10	AA9
CLKB[7]	MGTREFCLK_128	LVPECL	AA32	AA33
CLKB[8]	MGTREFCLK_130	LVPECL	N32	N33
CLKB[9]	MGTREFCLK_229	LVPECL	W10	W9

Table 11 : CLKB Connections

Note: CLKB[9:0] are all buffered copies of the same clock signal.

3.6.5 Module to Carrier Global Clocks (CLK_M2C)

A connected FMC+ board can generate a number of differential Global clocks (as per the FMC standard). They each connect to a global clock input on the FPGA.

Signal	Frequency	FPGA Input	IO Standard	"P" pin	"N" pin
CLK_M2C_0	Variable	Bank 71	LVDS	F23	F22
CLK_M2C_1	Variable	Bank 71	LVDS	G22	G21
CLK_M2C_2	Variable	Bank 70	LVDS	H25	H26
CLK_M2C_3	Variable	Bank 70	LVDS	H24	G25

Table 12 : CLK_M2C Connections

3.6.6 Module to Carrier MGTREF Clocks (GBTCLK_M2C)

A connected FMC board can generate a number of differential MGT Reference clocks (as per the FMC standard). They each connect to an MGTREFCLK input on the FPGA.

Signal	Frequency	FPGA Input	IO Standard	"P" pin	"N" pin
GBTCLK_0_M2C	Variable	MGTREFCLK_128	LVDS	AB34	AB35
GBTCLK_1_M2C	Variable	MGTREFCLK_129	LVDS	W32	W33
GBTCLK_2_M2C	Variable	MGTREFCLK_130	LVDS	R32	R33
GBTCLK_3_M2C	Variable	MGTREFCLK_131	LVDS	L32	L33
GBTCLK_4_M2C	Variable	MGTREFCLK_229	LVDS	Y12	Y11
GBTCLK_5_M2C	Variable	MGTREFCLK_230	LVDS	V12	V11

Table 13 : GCLK_M2C Connections

3.6.7 PS_REFCLK

The PS reference clock is an independent 50.0MHz reference clock. This is the master clock of the PS side of the MPSoC.

Signal	Frequency	FPGA Input	IO Standard	pin
PS_REFCLK	50MHz	PS_REF_CLK (Bank 503)	LVCOS33	AC27

Table 14 : PS_REFCLK Connection

3.7 Resets

The Zynq PS can be reset via two switches, SW1-5 and SW1-6.

Switch	Reset Type	Effect
SW1-5	Power on Reset (PS_POR_B pin)	Clears all logic. Mode pins sampled (i.e. reconfigures hardware). Reboots MPSoC.
SW1-6	Soft Reset (PS_SRST_B pin)	Same as Power on Reset - but does not sample Mode pins (hardware configuration unchanged).

Table 15 : Reset Switches

3.8 Zynq PS Block

3.8.1 Boot Modes

PS_MODE3 (SW1-4)	PS_MODE2 (SW1-3)	PS_MODE1 (SW1-2)	PS_MODE0 (SW1-1)	Boot Mode
ON	ON	ON	ON	JTAG
ON	ON	ON	OFF	Quad SPI (24 bit addressing)
ON	ON	OFF	ON	Quad SPI (32 bit addressing)
ON	ON	OFF	OFF	SD Flash - SD 2.0

Table 16 : Boot Mode Selection

Note: all other possible switch settings are reserved / invalid.

3.8.2 PS Memory Interfaces

The memory devices attached to the PS side of the MPSoC are outlined below.

3.8.2.1 Quad SPI Flash Memory

The ADM-VPX3-9Z5 has two Quad SPI Flash devices, up to 512Mb each. They can be interfaced separately in x1,x2,x4 modes or together in x8 mode.

3.8.2.2 MicroSD Card

The ADM-VPX3-9Z5 can interface to a MicroSD card (SD 2.0 standard at 3.3V).

The uSD card should be fitted in socket U110.

3.8.2.3 PS DDR4 Memory

The PS side of the MPSoC is connected to 1 bank of DDR4-2400 SDRAM, 1GB x72, 8GB total + ECC

3.8.3 PS MIO

11 PS MIO pins are available on VPX connector P1, which can be used to connect internal PS peripherals

through to an RTM module.

Group	FPGA Bank	Name	Function
GPIO_3	PS501	PSMIO(10:0)	11 single-ended

Table 17 : VPX PS MIO Groups

3.8.4 PS MGT Links

There are a total of 4 Multi-Gigabit Transceiver (MGT) links connected to the PS side of the FPGA:

Links	Banks	Width	Max Rate	Connection
PS_GTR (1:0)	505	2	6Gbps	GTR links to VPX P1 Connector Ctrl planes (2 ultra thin pipes)
PS_GTR (3:2)	505	2	6Gbps	GTR links to VPX P1 Connector user defined area

Table 18 : PS MGT Links

3.9 Zynq PL Block

3.9.1 I/O Bank Voltages

The FPGA IO is arranged in banks, each with their own supply pins. The bank numbers, their voltage and function are shown in [PL FPGA IO Banks](#).

IO Banks	Voltage	Purpose
68, 70, 71	FMC_VADJ	FMC+ GPIO - LA and HA
69	FMC_VIO_B	FMC+ GPIO - HB
48	1.8V or 1.2V	VPX P2 Differential GPIO
64, 65, 66	1.2V	PL DDR4 Banks
94	3.3V	VPX P2 Single Ended GPIO
93	3.3V	Setup and Control
90, 91	3.3V	Unused

Table 19 : PL FPGA IO Banks

3.9.2 PL MGT Links

There are a total of 48 Multi-Gigabit Transceiver (MGT) links connected to the FPGA, 4 of which are unused. These are connected as follows:

Links	Banks	Width	Max Rate	Connection
HSSIO(15:0)	128, 129, 130, 131	16	28Gbps	GTU links to FMC+ Socket (J3)
HSSIO(23:16)	229, 230	8	16Gbps	GTH links to FMC+ Socket (J3)
VPX_HSSIO(7:0)	224, 225	8	16Gbps	VPX P1 Connector Data Planes (2 fat pipes)

Table 20 : PL MGT Links (continued on next page)

Links	Banks	Width	Max Rate	Connection
VPX_HSSIO(19:8)	224, 225	12	16Gbps	VPX P2 Connector User Defined Area
UNUSED(3:0)	231	4	-	unused - not routed out

Table 20 : PL MGT Links

3.9.3 FMC+ GPIO Interface

The FMC+ Connector (J3) has GPIO connections arranged as follows:

Group	FPGA Bank	Name	Function
LA_0	71	LA(16:2)	14 diff. Pairs / 28 single-ended
		LA_CC (1:0)	2x Regional Clocks / GPIO pairs / 4 single-ended
LA_1	70	LA(33:19)	15 diff. Pairs / 30 single-ended
		LA_CC (18:17)	2x Regional Clocks / GPIO pairs / 4 single-ended
HA_0	68	HA(16:2)	15 diff. Pairs / 30 single-ended
		HA_CC (1:0)	2x Regional Clocks / GPIO pairs / 4 single-ended
		HA(23:18)	6 diff. Pairs / 12 single-ended
		HA_CC (17)	Regional Clock / GPIO pair / 2 single-ended
HB_0	69	HB(5:1)	5 diff. Pairs / 10 single-ended
		HB(16:7)	10 diff. Pairs / 20 single-ended
		HB(21:18)	4 diff. Pairs / 8 single-ended
		HB_CC (0)	Regional Clock / GPIO pair / 2 single-ended
		HB_CC (6)	Regional Clock / GPIO pair / 2 single-ended
		HB_CC (17)	Regional Clock / GPIO pair / 2 single-ended

Table 21 : FMC+ Groups (J1)

3.9.4 VPX P1 GPIO Interface

The P1 VPX Connector has GPIO connections arranged as follows:

Group	FPGA Bank	Name	Function
GPIO_1	67	VPX_GPIO(23:16)	4 diff. Pairs / 8 single-ended

Table 22 : VPX P1 GPIO Groups

3.9.5 VPX P2 GPIO Interface

The P2 VPX Connector has GPIO connections arranged as follows:

Group	FPGA Bank	Name	Function
GPIO_0	67	VPX_GPIO(15:0)	8 diff. Pairs / 16 single-ended
GPIO_2	94	VPX_SE_GPIO(7:0)	8 single-ended

Table 23 : VPX P2 GPIO Groups

3.9.6 PL DDR4 Memory

The PL side of the MPSoC is connected to 1 bank of DDR4-2400 SDRAM, 1GB x72, 8GB total + ECC

3.10 System Monitoring

The **9Z5** has the ability to monitor temperature and voltage to maintain a check on the operation of the board. The monitoring is implemented using a TI MSP430 microcontroller (uC).

The microcontroller continually measures all voltage rails and temperature sensors and transmits the results to the FPGA, where they can be stored in blockram.

The following voltage rails and temperatures are monitored by the microcontroller:

Monitor	Purpose
12V0	12V Board Input Supply Voltage
5V0	5V Board Input Supply Voltage
3V3	Board Input Supply Voltage
FMC_VADJ	Variable FMC IO Supply Voltage
0V85	FPGA Core Voltage
1V8_DIG	FPGA PL side IO Supply Voltage
1V8_PSAUX	FPGA PS Aux Supply Voltage
PS_AUXIO	FPGA PS Aux IO Supply Voltage
1V8_PSAUX	FPGA PS Aux Supply Current
PS_AUXIO	FPGA PS Aux IO Supply Current
1V8_DIG	FPGA PL side IO Supply Current
12V0	12V Board Input Supply Current
Temp(1)	microcontroller internal temperature
Temp(4..2)	TMP422-EP internal temperatures (3 devices)
Temp(5)	FPGA on-die temperature (measured by TMP422-EP)
Temp(10..6)	pcb temperatures (5 different points - measured by TMP422-EP devices)

Table 24 : Voltage and Temperature Monitors (in microcontroller)

3.10.1 Automatic Temperature Monitoring

The system monitor checks that the board and FPGA are being operated within the specified limits. If the temperature is close to the limit, a "Warning Alarm" interrupt is set.

If a limit is exceeded, a "Critical Alarm" interrupt is set. After the Critical Alarm is set, there is a 5 second delay before the system monitor unconfigures the FPGA by asserting its "PROG" pin.

The purpose of this mechanism is to protect the card from damage due to over-temperature. It is possible that it will cause the user application and, possibly, the host computer to "hang".

The temperature limits are shown in Table Temperature Limits. Note that the Min and Max values include a 5°C margin to prevent measurement errors triggering a false alarm.

	Target FPGA				Board (uC and PCB)			
	Min	Lower Warning	Upper Warning	Max	Min	Lower Warning	Upper Warning	Max
Extended	-5°C	+5°C	+95°C	+105°C	-5°C	+5°C	+80°C	+90°C
Industrial	-45°C	-35°C	+95°C	+105°C	-45°C	-35°C	+80°C	+90°C
Military	-60°C	-50°C	+140°C	+170°C	-60°C	-50°C	+125°C	+135°C

Table 25 : Temperature Limits

3.10.2 System Monitor Status LEDs

LEDs D3 (Green) and D6 (Red) indicate the microcontroller status.

LEDs	Status
Flashing Green + Flashing Red (alternate)	Service Mode
Red	Missing application firmware or invalid firmware
Red + Green	Standby (Powered off)
Green	Running and no alarms
Flashing Green + Red	Attention - alarm active
Flashing Green + Flashing Red (together)	Attention - critical alarm active
Flashing Red	FPGA configuration cleared to protect board

Table 26 : System Monitor Status LEDs

3.11 FMC Interface and Front-Panel I/O

The FMC+ interface provides a high-performance and flexible front-panel interface through a range of interchangeable, industry standard IO modules which connect at receptacle J3.

The FMC+ interface adheres to VITA 57.4. The ADM-VPX3-9Z5 utilizes all possible FMC+ connectivity. This includes all GPIO, all MGT links, and all clock capable IO.

FMC I2C signal (SCL and SDA at C30 and C31) are connected to the system monitor microcontroller. They are used to determine operating voltage during startup and are not accessible to the user.

The FMC Present signal (PRSENT_M2C_L at connector pin H2) is connected to the system monitor microcontroller.

Note:

The ADM-VPX3-9Z5 supports only 1.8V and lower VADJ Voltages.

Page Intentionally left blank

Appendix A: P1 Pin Assignments

Appendix A.1: Data Plane 1 (P1 Wafers 1-4)

Signal	VPX P1	FPGA		FPGA	VPX P1	Signal
P1_TX0_P	D1	AY4		BA2	A1	P1_RX0_P
P1_TX0_N	E1	AY3		BA1	B1	P1_RX0_N
P1_TX1_P	E2	AW6		AW2	B2	P1_RX1_P
P1_TX1_N	F2	AW5		AW1	C2	P1_RX1_N
P1_TX2_P	D3	AU6		AV4	A3	P1_RX2_P
P1_TX2_N	E3	AU5		AV3	B3	P1_RX2_N
P1_TX3_P	E4	AT8		AU2	B4	P1_RX3_P
P1_TX3_N	F4	AT7		AU1	C4	P1_RX3_N

Table 27 : Data Plane 1 (P1 Wafers 1-4)

Appendix A.2: Data Plane 2 (P1 Wafers 5-8)

Signal	VPX P1	FPGA		FPGA	VPX P1	Signal
P1_TX4_P	D5	AR6		AT4	A5	P1_RX4_P
P1_TX4_N	E5	AR5		AT3	B5	P1_RX4_N
P1_TX5_P	E6	AP8		AR2	B6	P1_RX5_P
P1_TX5_N	F6	AP7		AR1	C6	P1_RX5_N
P1_TX6_P	D7	AN6		AP4	A7	P1_RX6_P
P1_TX6_N	E7	AN5		AP3	B7	P1_RX6_N
P1_TX7_P	E8	AM8		AN2	B8	P1_RX7_P
P1_TX7_N	F8	AM7		AN1	C8	P1_RX7_N

Table 28 : Data Plane 2 (P1 Wafers 5-8)

Appendix A.3: User Plane PS GTR(P1 Wafers 9-10)

Signal	VPX P1	FPGA		FPGA	VPX P1	Signal
PS_TX2_P	D9	AD39		AC41	A9	PS_RX2_P
PS_TX2_N	E9	AD40		AC42	B9	PS_RX2_N
PS_TX3_P	E10	AB39		AA41	B10	PS_RX3_P
PS_TX3_N	F10	AB40		AA42	C10	PS_RX3_N

Table 29 : User Plane PS GTR(P1 Wafers 9-10)

Appendix A.4: User Plane GPIO(P1 Wafers 11-12)

Signal	VPX P1	FPGA		FPGA	VPX P1	Signal
GP9_1V8_P	A11	AW11		AU11	D11	GP10_1V8_P
GP9_1V8_N	B11	AW10		AV11	E11	GP10_1V8_N
GP11_1V8_P	B12	AV12		BB5	E12	GP12_1V8_P
GP11_1V8_N	C12	AW12		BB4	F12	GP12_1V8_N

Table 30 : User Plane GPIO(P1 Wafers 11-12)

Appendix A.5: User Plane PS MIO(P1 Wafers 9-14)

Signal	VPX P1	FPGA		FPGA	VPX P1	Signal
PS_MIO_2	D13	T27		P27	A13	PS_MIO_0
PS_MIO_3	E13	N30		N29	B13	PS_MIO_1
PS_MIO_6	E14	R27		V29	B14	PS_MIO_4
PS_MIO_7	F14	P29		W30	C14	PS_MIO_5
PS_MIO_8	G9	P28		P30	G11	PS_MIO_9
PS_MIO_10	G13	M28		-	-	-

Table 31 : User Plane PS MIO(P1 Wafers 9-14)

Appendix A.6: Control Plane (P1 Wafers 15-16)

Signal	VPX P1	FPGA		FPGA	VPX P1	Signal
PS_TX1_P	D15	AF39		AE41	A15	PS_RX1_P
PS_TX1_N	E15	AF40		AE42	B15	PS_RX1_N
PS_TX0_P	E16	AH39		AG41	B16	PS_RX0_P
PS_TX0_N	F16	AH40		AG42	C16	PS_RX0_N

Table 32 : Control Plane (P1 Wafers 15-16)

Appendix B: P2 Pin Assignments

Appendix B.1: GPIO (P2 Wafers 1-4)

Signal	VPX P2	FPGA	FPGA	VPX P2	Signal
GP1_N	F4	AK14	AN10	E1	GP7_N
GP1_P	E4	AJ14	AM10	D1	GP7_P
GP2_N	C4	AN13	AN11	B1	GP8_N
GP2_P	B4	AM13	AM11	A1	GP8_P
GP3_N	E3	AP14	B1	G1	GP_SE_3V3_<0>
GP3_P	D3	AN14	C4	G3	GP_SE_3V3_<1>
GP4_N	B3	AM14	C3	G5	GP_SE_3V3_<2>
GP4_P	A3	AL14	C6	G7	GP_SE_3V3_<3>
GP5_N	F2	AK15	C5	G9	GP_SE_3V3_<4>
GP5_P	E2	AJ15	D2	G11	GP_SE_3V3_<5>
GP6_N	C2	AM15	C1	G13	GP_SE_3V3_<6>
GP6_P	B2	AL15	D4	G15	GP_SE_3V3_<7>

Table 33 : GPIO (P2 Wafers 1-4)

Appendix B.2: MGT Pins (P2 Wafers 5-16)

Signal	VPX P2	FPGA	FPGA	VPX P2	Signal
P2_RX0_N	B5	AM3	AL5	E5	P2_TX0_N
P2_RX0_P	A5	AM4	AL6	D5	P2_TX0_P
P2_RX1_N	C6	AL1	AK7	F6	P2_TX1_N
P2_RX1_P	B6	AL2	AK8	E6	P2_TX1_P
P2_RX2_N	B7	AK3	AJ5	E7	P2_TX2_N
P2_RX2_P	A7	AK4	AJ6	D7	P2_TX2_P
P2_RX3_N	C8	AJ1	AH7	F8	P2_TX3_N
P2_RX3_P	B8	AJ2	AH8	E8	P2_TX3_P
P2_RX4_N	B9	AH3	AG5	E9	P2_TX4_N
P2_RX4_P	A9	AH4	AG6	D9	P2_TX4_P
P2_RX5_N	C10	AG1	AF7	F10	P2_TX5_N
P2_RX5_P	B10	AG2	AF8	E10	P2_TX5_P
P2_RX6_N	B11	AF3	AE5	E11	P2_TX6_N
P2_RX6_P	A11	AF4	AE6	D11	P2_TX6_P

Table 34 : MGT (P2 Wafers 5-16) (continued on next page)

Signal	VPX P2	FPGA		FPGA	VPX P2	Signal
P2_RX7_N	C12	AE1		AD7	F12	P2_TX7_N
P2_RX7_P	B12	AE2		AD8	E12	P2_TX7_P
P2_RX8_N	B13	AD3		AC5	E13	P2_TX8_N
P2_RX8_P	A13	AD4		AC6	D13	P2_TX8_P
P2_RX9_N	C14	AC1		AB7	F14	P2_TX9_N
P2_RX9_P	B14	AC2		AB8	E14	P2_TX9_P
P2_RX10_N	C16	AB3		AA5	F16	P2_TX10_N
P2_RX10_P	B16	AB4		AA6	E16	P2_TX10_P
P2_RX11_N	B15	AA1		Y7	E15	P2_TX11_N
P2_RX11_P	A15	AA2		Y8	D15	P2_TX11_P

Table 34 : MGT (P2 Wafers 5-16)

Appendix C: FMC Pin Assignments

Appendix C.1: GPIO Pins

Signal	FMC (J3)	FPGA	FPGA	FPGA	FMC (J3)	Signal
LA00_CC_N	G7	G20	E14	F5	HA00_CC_N	
LA00_CC_P	G6	H21	F14	F4	HA00_CC_P	
LA01_CC_N	D9	H19	F15	E3	HA01_CC_N	
LA01_CC_P	D8	H20	G16	E2	HA01_CC_P	
LA02_N	H8	E20	N15	K8	HA02_N	
LA02_P	H7	F20	P15	K7	HA02_P	
LA03_N	G10	E19	L15	J7	HA03_N	
LA03_P	G9	F19	M15	J6	HA03_P	
LA04_N	H11	J19	K15	F8	HA04_N	
LA04_P	H10	K19	K16	F7	HA04_P	
LA05_N	D12	K20	G15	E7	HA05_N	
LA05_P	D11	L20	H15	E6	HA05_P	
LA06_N	C11	L19	M16	K11	HA06_N	
LA06_P	C10	M20	M17	K10	HA06_P	
LA07_N	H14	B20	N16	J10	HA07_N	
LA07_P	H13	C20	P16	J9	HA07_P	
LA08_N	G13	C19	K17	F11	HA08_N	
LA08_P	G12	D19	L17	F10	HA08_P	
LA09_N	D15	J21	A12	E10	HA09_N	
LA09_P	D14	K21	B13	E9	HA09_P	
LA10_N	C15	J22	D17	K14	HA10_N	
LA10_P	C14	K22	E17	K13	HA10_P	
LA11_N	H17	D22	H18	J13	HA11_N	
LA11_P	H16	E22	J18	J12	HA11_P	
LA12_N	G16	B21	F17	F14	HA12_N	
LA12_P	G15	C21	G17	F13	HA12_P	
LA13_N	D18	A23	H16	E13	HA13_N	
LA13_P	D17	B23	J16	E12	HA13_P	
LA14_N	C19	D21	C18	J16	HA14_N	
LA14_P	C18	E21	D18	J15	HA14_P	
LA15_N	H20	A22	C13	F17	HA15_N	

Table 35 : GPIO Pins (continued on next page)

Signal	FMC (J3)	FPGA	FPGA	FPGA	FMC (J3)	Signal
LA15_P	H19	B22	D13	F16	HA15_P	
LA16_N	G19	A19	F18	E16	HA16_N	
LA16_P	G18	A20	G18	E15	HA16_P	
LA17_CC_N	D21	G27	D14	K17	HA17_CC_N	
LA17_CC_P	D20	G26	E15	K16	HA17_CC_P	
LA18_CC_N	C23	E25	A17	J19	HA18_N	
LA18_CC_P	C22	F25	B17	J18	HA18_P	
LA19_N	H23	N25	A13	F20	HA19_N	
LA19_P	H22	N24	A14	F19	HA19_P	
LA20_N	G22	N23	D16	E19	HA20_N	
LA20_P	G21	P23	E16	E18	HA20_P	
LA21_N	H26	A28	A18	K20	HA21_N	
LA21_P	H25	A27	B18	K19	HA21_P	
LA22_N	G25	L23	B15	J22	HA22_N	
LA22_P	G24	M23	C15	J21	HA22_P	
LA23_N	D24	L25	B16	K23	HA23_N	
LA23_P	D23	M25	C16	K22	HA23_P	
LA24_N	H29	G23	C31	K26	HB00_CC_N	
LA24_P	H28	H23	C30	K25	HB00_CC_P	
LA25_N	G28	B26	F32	J25	HB01_N	
LA25_P	G27	B25	F31	J24	HB01_P	
LA26_N	D27	K24	H28	F23	HB02_N	
LA26_P	D26	L24	J28	F22	HB02_P	
LA27_N	C27	J26	A30	E22	HB03_N	
LA27_P	C26	K26	A29	E21	HB03_P	
LA28_N	H32	E27	H30	F26	HB04_N	
LA28_P	H31	E26	J30	F25	HB04_P	
LA29_N	G31	F28	F29	E25	HB05_N	
LA29_P	G30	F27	G28	E24	HB05_P	
LA30_N	H35	D28	D32	K29	HB06_CC_N	
LA30_P	H34	D27	E32	K28	HB06_CC_P	
LA31_N	G34	B28	F30	J28	HB07_N	
LA31_P	G33	C28	G30	J27	HB07_P	
LA32_N	H38	J27	D29	F29	HB08_N	
LA32_P	H37	K27	E29	F28	HB08_P	
LA33_N	G37	B27	C33	E28	HB09_N	

Table 35 : GPIO Pins (continued on next page)

Signal	FMC (J3)	FPGA		FPGA	FMC (J3)	Signal
LA33_P	G36	C26		D33	E27	HB09_P
HB16_N	F35	C37		A38	K32	HB10_N
HB16_P	F34	C36		A37	K31	HB10_P
HB17_CC_N	K38	B33		B30	J31	HB11_N
HB17_CC_P	K37	B32		C29	J30	HB11_P
HB18_N	J37	A34		A32	F32	HB12_N
HB18_P	J36	A33		B31	F31	HB12_P
HB19_N	E34	A40		A35	E31	HB13_N
HB19_P	E33	A39		B35	E30	HB13_P
HB20_N	F38	C34		B42	K35	HB14_N
HB20_P	F37	D34		C42	K34	HB14_P
HB21_N	E37	B37		B41	J34	HB15_N
HB21_P	E36	B36		B40	J33	HB15_P
FMC_CLK_DIR	B1	J17		-	-	-

Table 35 : GPIO Pins

Appendix C.2: Clock Pins

Signal	FMC (J3)	FPGA		FPGA	FMC (J3)	Signal
CLK0_M2C_N	H5	F22		H26	K5	CLK2_BIDIR_N
CLK0_M2C_P	H4	F23		H25	K4	CLK2_BIDIR_P
CLK1_M2C_N	G3	G21		G25	J3	CLK3_BIDIR_N
CLK1_M2C_P	G2	G22		H24	J2	CLK3_BIDIR_P
GBTCLK0_M2C_N	D5	AB35		L33	L9	GBTCLK3_M2C_N
GBTCLK0_M2C_P	D4	AB34		L32	L8	GBTCLK3_M2C_P
GBTCLK1_M2C_N	B21	W33		Y11	L5	GBTCLK4_M2C_N
GBTCLK1_M2C_P	B20	W32		Y12	L4	GBTCLK4_M2C_P
GBTCLK2_M2C_N	L13	R33		V11	Z21	GBTCLK5_M2C_N
GBTCLK2_M2C_P	L12	R32		V12	Z20	GBTCLK5_M2C_P

Table 36 : Clock Pins

Appendix C.3: MGT Pins

Signal	FMC (J3)	FPGA	FPGA	FPGA	FMC (J3)	Signal
DP0_M2C_N	C7	W42	Y35	C3	DP0_C2M_N	
DP0_M2C_P	C6	W41	Y34	C2	DP0_C2M_P	
DP1_M2C_N	A3	V40	W37	A23	DP1_C2M_N	
DP1_M2C_P	A2	V39	W36	A22	DP1_C2M_P	
DP2_M2C_N	A7	U42	V35	A27	DP2_C2M_N	
DP2_M2C_P	A6	U41	V34	A26	DP2_C2M_P	
DP3_M2C_N	A11	T40	U37	A31	DP3_C2M_N	
DP3_M2C_P	A10	T39	U36	A30	DP3_C2M_P	
DP4_M2C_N	A15	R42	T35	A35	DP4_C2M_N	
DP4_M2C_P	A14	R41	T34	A34	DP4_C2M_P	
DP5_M2C_N	A19	P40	R37	A39	DP5_C2M_N	
DP5_M2C_P	A18	P39	R36	A38	DP5_C2M_P	
DP6_M2C_N	B17	N42	P35	B37	DP6_C2M_N	
DP6_M2C_P	B16	N41	P34	B36	DP6_C2M_P	
DP7_M2C_N	B13	M40	N37	B33	DP7_C2M_N	
DP7_M2C_P	B12	M39	N36	B32	DP7_C2M_P	
DP8_M2C_N	B9	L42	M35	B29	DP8_C2M_N	
DP8_M2C_P	B8	L41	M34	B28	DP8_C2M_P	
DP9_M2C_N	B5	K40	L37	B25	DP9_C2M_N	
DP9_M2C_P	B4	K39	L36	B24	DP9_C2M_P	
DP10_M2C_N	Y11	J42	K35	Z25	DP10_C2M_N	
DP10_M2C_P	Y10	J41	K34	Z24	DP10_C2M_P	
DP11_M2C_N	Z13	H40	J37	Y27	DP11_C2M_N	
DP11_M2C_P	Z12	H39	J36	Y26	DP11_C2M_P	
DP12_M2C_N	Y15	G42	H35	Z29	DP12_C2M_N	
DP12_M2C_P	Y14	G41	H34	Z28	DP12_C2M_P	
DP13_M2C_N	Z17	F40	G37	Y31	DP13_C2M_N	
DP13_M2C_P	Z16	F39	G36	Y30	DP13_C2M_P	
DP14_M2C_N	Y19	E42	F35	M19	DP14_C2M_N	
DP14_M2C_P	Y18	E41	F34	M18	DP14_C2M_P	
DP15_M2C_N	Y23	D40	E37	M23	DP15_C2M_N	
DP15_M2C_P	Y22	D39	E36	M22	DP15_C2M_P	
DP16_M2C_N	Z33	Y3	W5	M27	DP16_C2M_N	
DP16_M2C_P	Z32	Y4	W6	M26	DP16_C2M_P	

Table 37 : MGT Pins (continued on next page)

Signal	FMC (J3)	FPGA		FPGA	FMC (J3)	Signal
DP17_M2C_N	Y35	W1		V7	M31	DP17_C2M_N
DP17_M2C_P	Y34	W2		V8	M30	DP17_C2M_P
DP18_M2C_N	Z37	V3		U5	M35	DP18_C2M_N
DP18_M2C_P	Z36	V4		U6	M34	DP18_C2M_P
DP19_M2C_N	Y39	U1		T7	M39	DP19_C2M_N
DP19_M2C_P	Y38	U2		T8	M38	DP19_C2M_P
DP20_M2C_N	M15	T3		R5	Z9	DP20_C2M_N
DP20_M2C_P	M14	T4		R6	Z8	DP20_C2M_P
DP21_M2C_N	M11	R1		P7	Y7	DP21_C2M_N
DP21_M2C_P	M10	R2		P8	Y6	DP21_C2M_P
DP22_M2C_N	M7	P3		N5	Z5	DP22_C2M_N
DP22_M2C_P	M6	P4		N6	Z4	DP22_C2M_P
DP23_M2C_N	M3	N1		M7	Y3	DP23_C2M_N
DP23_M2C_P	M2	N2		M8	Y2	DP23_C2M_P

Table 37 : MGT Pins

Revision History

Date	Revision	Nature of Change
13 May 2020	0.1	Initial Draft
27 July 2020	0.2	Updated images
08 June 2021	1.0	Production Release
10 Nov 2021	1.1	Updated FMC GPIO table
19 Jan 2022	1.2	Updated P1 pinout table
30 May 2022	1.3	Updated FMC+ MGT pinout table